

ET553XX - 500mA Low Dropout LDO

General Description

The ET553XX series are CMOS-based low-dropout, low-power linear regulators, offering 500mA with low dropout voltage, high ripple rejection, high output accuracy and low supply current. The ET553XX series consist of an accurate voltage-reference block, an error amplifier, a voltage-setting resistor net, a PMOSFET pass device, a thermal-shutdown circuit, and a current limit circuit with short protection.

The ET553XX series use a type of outstanding CMOS process to minimize the supply current. A low on-resistance PMOS pass device is equipped for lower dropout voltage. ET553XX also possess the EN function to save more energy and extend the battery life.

Features

- Wide Input Voltage Range: 1.9V to 5.5V
- Output Current: 500mA optional
- Output Voltage Range: 1.0V to 3.6V (Fixed or externally set)
- Very Low IQ: 50 μ A
- Excellent Load / Line Transient Response
- Built-in Over Current Protection and Thermal Shutdown circuit
- Built-in Inrush Current Suppression circuit and Current Limit
- Built-in Auto-discharging circuit
- Package: DFN4 (1 \times 1), DFN4 (1.2 \times 1.2), SOT23-3, SOT23-5, SOT89-3, SOT89-5, SC70-5

Applications

- Constant-voltage power supply for battery-powered device
- Constant-voltage power supply for TV, notebook PC and home electric appliance
- Constant-voltage power supply for portable equipment

ET553XX

Device Information

ET 553 XX/ADJ X B

<u>XX/ADJ</u> Output Voltage	<u>X</u> Package		<u>B</u> Auto-Discharging Function	MSL
XX - Fixed X.XV ADJ - Adjustable by resistive divider	Y	DFN4(1X1)	B - Available	1
	Y(ADJ)	DFN4(1.2X1.2)		1
	B	SOT89-3		3
	T	SOT89-5		3
	S	SOT23-3		3
	/	SOT23-5		3
	SC	SC70-5		3

Pin Function

Pin No.						Pin Name	Pin Function
DFN4(1×1)	DFN4(1.2×1.2)	SOT23-3	SOT23-5/SC70-5	SOT89-3	SOT89-5		
2	5	1	2	1	2	GND	Ground
4	4	2	1	2	4	IN	Supply input pin
1	1	3	5	3	5	OUT	Output pin
3	3	/	3	/	3	EN	Enable control input, active high
/	2	/	4 (NC)	/	1	FB	Set the output voltage

ET553XX

Pin Configuration

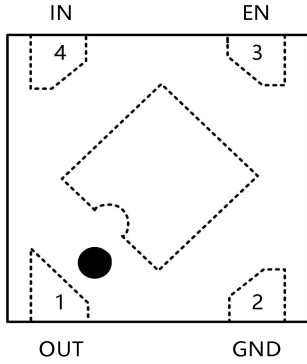

DFN4(1X1) (Fixed version)

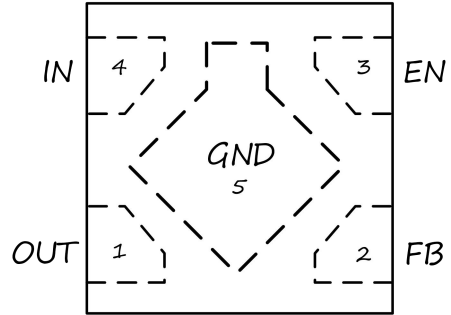

DFN4(1.2X1.2) (ADJ version)

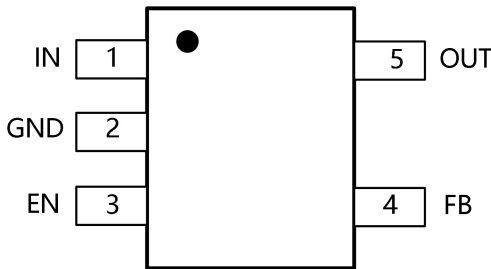

ET553ADJ (ADJ version)

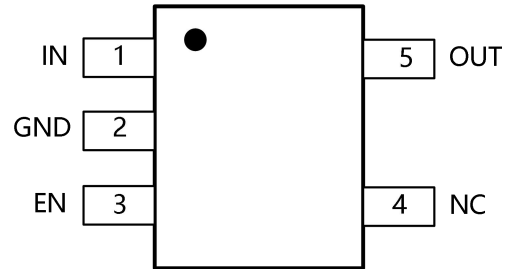

ET553XX/ET553XXSC (Fixed version)

SOT23-5/SC70-5

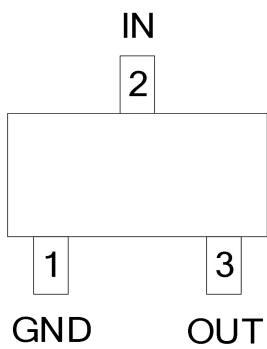

SOT23-3(Fixed version)

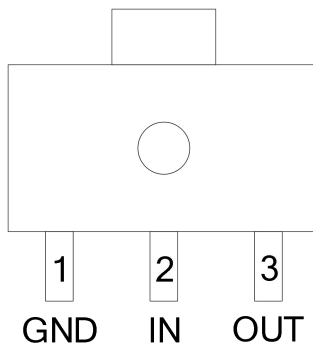

SOT89-3 (Fixed version)

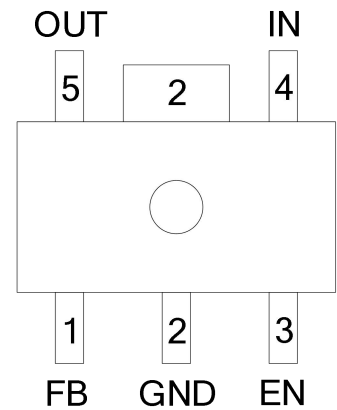

SOT89-5 (ADJ version)

TOP VIEW

ET553XX

Current Limit Protection

When output current of VOUT pin is higher than current limit threshold or the VOUT pin is direct short to GND, the current limit protection will be triggered and clamp the output current at a predesigned level to prevent over-current and thermal damage.

Thermal Shutdown Protection

Thermal protection disables the output when the junction temperature rises to approximately +155°C, allowing to cool down. When the junction temperature reduce to approximately +130°C the output circuit is enabled again. Depending on power dissipation, thermal resistance and ambient temperature, the thermal protection circuit may cycle on and off. This cycling limits the heat dissipation of the regulator, protecting it from damage due to overheating.

Auto Discharging

When the EN pin set to “L”, the output circuit will be disable immediately, and the Auto-Discharging circuit will be turned on to discharge the electric charge on output capacitor, and decrease the voltage of VOUT in very short time. The Auto-Discharging function is optional.

Output Voltage

The output voltage is adjustable using external 2 resistors. For better performance of the circuit, the R2 value need to be between 100kΩ and 1MΩ. The output voltage is calculated by:

$$V_{OUT} = (1+R1/R2) \times 0.8 \text{ (V)}$$

ET553XX

Absolute Maximum Ratings

Symbol	Item	Rating	Unit
V _{IN}	Input Voltage (IN Pin)	-0.3 to 6.0	V
V _{EN}	Input Voltage (EN Pin) (If)	-0.3 to 6.0	V
V _{FB}	Input Voltage (FB Pin)	-0.3 to 6.0	V
V _{OUT}	Output Voltage (OUT Pin)	-0.3 to 6.0	V
T _J	Junction Temperature Range	-40 to +150	°C
T _{STG}	Storage Temperature Range	-65 to +150	°C
V _{ESD}	HBM (ESDA/JEDEC JS-001-2017)	±4.0	kV
	CDM (ESDA/JEDEC JS-002-2014)	±1.5	kV
I _{LU}	Latch up Current Maximum Rating (JESD78E)	±200	mA

Thermal Characteristics

Symbol	Package	Ratings	Value	Unit
R _{θJA}	DFN4(1×1)	Thermal Characteristics, Thermal Resistance, Junction-to-Air	250	°C/W
	DFN4(1.2×1.2)		180	°C/W
	SOT23-3		TBD	°C/W
	SOT23-5		250	°C/W
	SC70-5		TBD	°C/W
	SOT89-3		TBD	°C/W
	SOT89-5		70	°C/W

Recommended Operating Conditions

Symbol	Parameters	Min	Max	Unit
V _{IN}	Input Voltage	1.9	5.5	V
I _{OUT}	Output Current	0	500	mA
T _A	Operating Ambient Temperature	-40	85	°C
C _{IN}	Input Ceramic Capacitor Value	0.47	10	uF
C _{OUT}	Output Ceramic Capacitor Value	0.47	10	uF
ESR	Input and Output Capacitor Equivalent Series Resistance	5	100	mΩ

ET553XX

Electrical Characteristics

$V_{IN} = V_{SET} + 1.0V$, $I_{OUT} = 1mA$, $C_{IN} = C_{OUT} = 2.2\mu F$, (unless otherwise noted). $T_A = 25^\circ C$.

Symbol	Item	Conditions	Min	Typ	Max	Unit
V_{IN}	Input Voltage		1.9		5.5	V
V_{OUT}	Output Voltage		$\times 0.98$		$\times 1.02$	V
V_{FB}	FB Voltage (If FB Pin Exist)	$T_A = 25^\circ C$	0.784	0.800	0.818	V
		$T_A = -40^\circ C \sim 85^\circ C$	0.776	0.800	0.824	V
$\frac{\Delta V_{OUT}}{\Delta I_{OUT}}$	Load Regulation	$V_{IN} = V_{SET} + 1V$, $1mA \leq I_{OUT} \leq 0.5A$		20	50	mV
V_{DIF}	Dropout Voltage	$1.0V \leq V_{SET} < 1.6V$, $I_{OUT} = 0.5A$, V_{OUT} dropping to $0.98 \times V_{SET}$			900	mV
		$1.7V \leq V_{SET} < 2.6V$, $I_{OUT} = 0.5A$, V_{OUT} dropping to $0.98 \times V_{SET}$		350	500	mV
		$2.6 \leq V_{SET} < 3.6V$, $I_{OUT} = 0.5A$, V_{OUT} dropping to $0.98 \times V_{SET}$		260	400	mV
I_{SS}	Supply Current	$I_{OUT} = 0mA$		50	85	μA
$I_{Standby}$	Standby Current (If EN Pin Exist)	$V_{EN} = 0V$		0	1	μA
$\frac{\Delta V_{OUT}}{\Delta V_{IN}}$	Line Regulation	$V_{SET} + 0.5V \leq V_{IN} \leq 5.5V$ ($V_{IN} \geq 1.4V$)		0.02		%/V
PSRR	Power Supply Rejection Ratio	$f = 1kHz$, Ripple $0.2Vp-p$, $V_{IN} = V_{SET} + 1.0V$, $I_{OUT} = 30mA$		80		dB
I_{LIM}	Output Current Limit	$V_{IN} = V_{SET} + 1V$		700	1200	mA
I_{Short}	Short Current Limit	$V_{OUT} = 0V$		150	240	mA
R_{PD}	EN Pull-down Resistance (If EN Pin Exist)			1M		Ω
V_{IH}	EN Input Voltage High (If EN Pin Exist)		0.9			V
V_{IL}	EN Input Voltage Low (If EN Pin Exist)				0.40	V
R_{DIS}	Auto-discharge Resistance (If EN Pin Exist)	$V_{IN} = 4V$, $V_{EN} = 0V$		80		Ω
T_{TSD}	Thermal Shutdown Temperature			155		$^\circ C$
T_{TSR}	Thermal Shutdown Released Temperature			130		$^\circ C$

ET553XX

Typical Characteristics

(1) VOLTAGE VERSION 1.1V

$V_{IN} = V_{SET} + 1.0V$, $I_{OUT} = 1mA$, $C_{IN} = C_{OUT} = 2.2\mu F$, (unless otherwise noted). $T_A = 25^\circ C$.

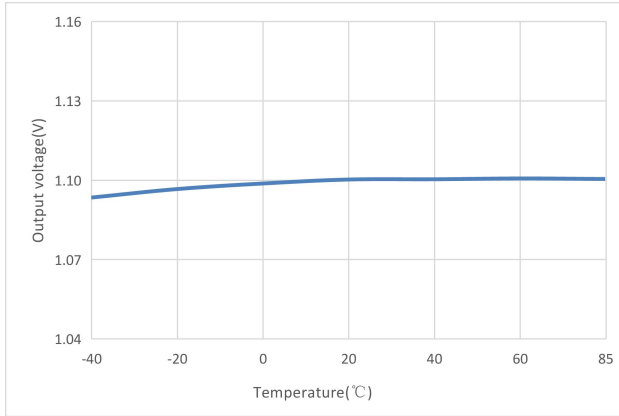

Output Voltage VS Temperature

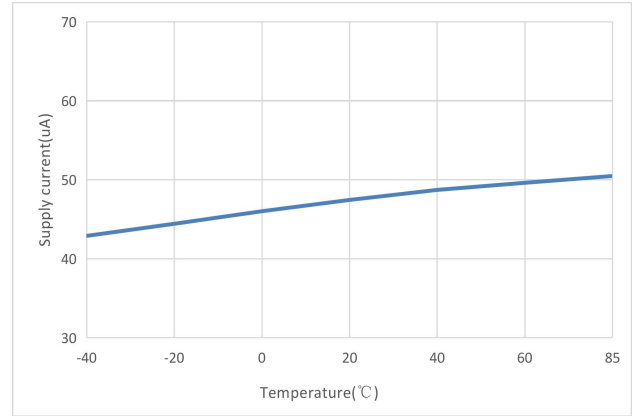

Supply Current VS Temperature

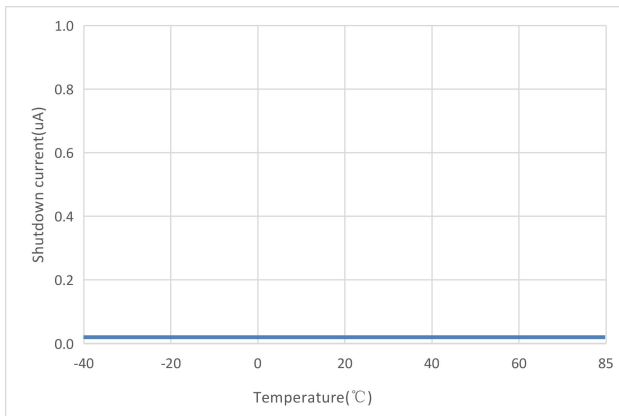

Shutdown Current VS Temperature

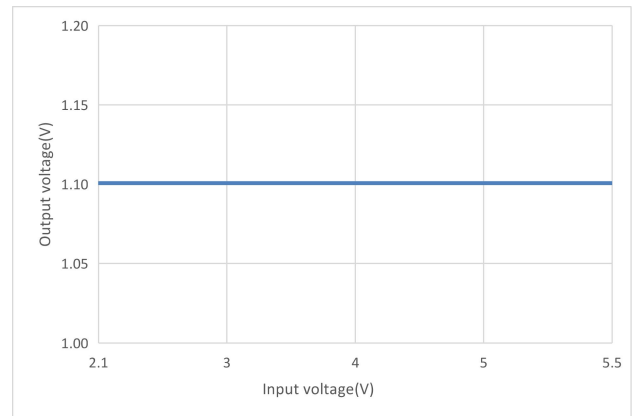

Output Voltage VS Input Voltage

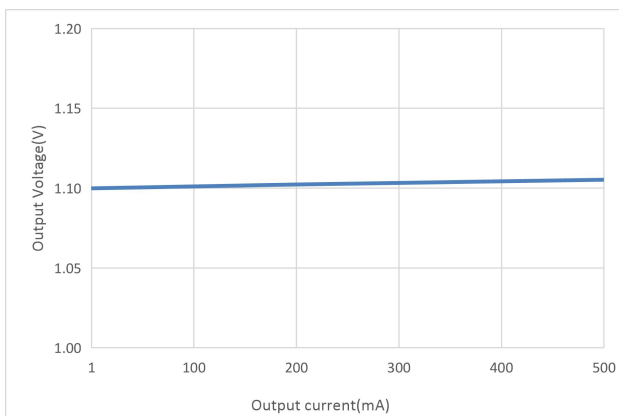

Output Voltage VS Output Current

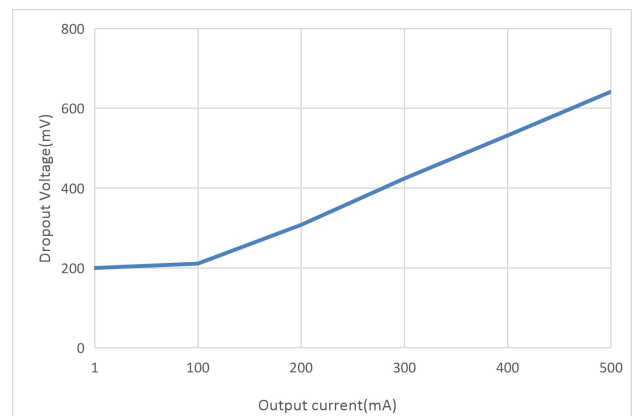

Dropout Voltage VS Output Current

ET553XX

Typical Characteristics(continued)

$V_{IN} = V_{SET} + 1.0V$, $I_{OUT} = 1mA$, $C_{IN} = C_{OUT} = 2.2\mu F$, (unless otherwise noted). $T_A = 25^\circ C$.

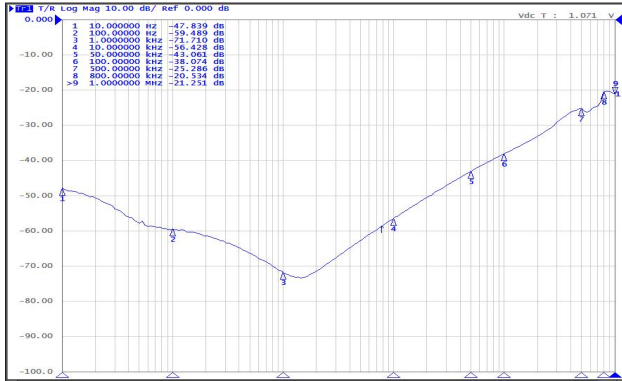

PSRR Test($I_{OUT}=30mA$)

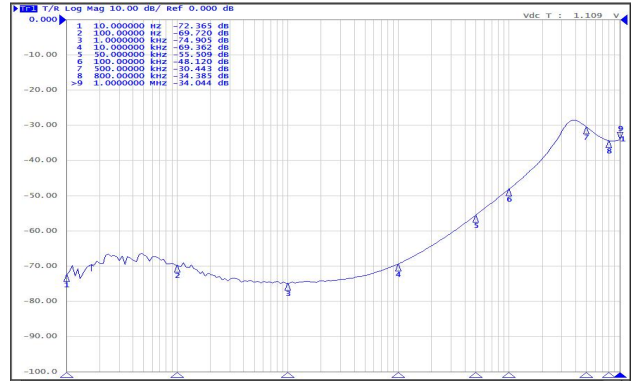

PSRR Test($I_{OUT}=0.5A$)

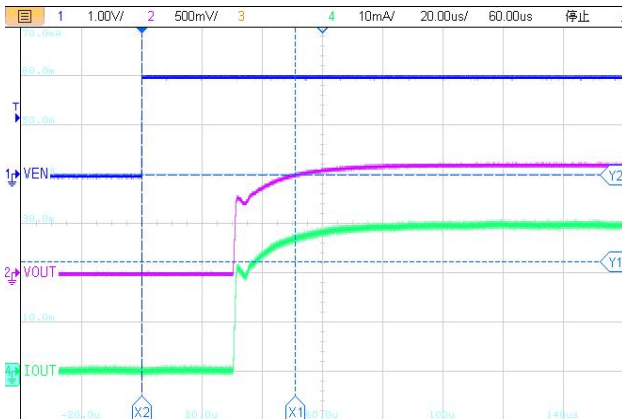

$t_{ON}=51\mu s(I_{OUT}=30mA)$

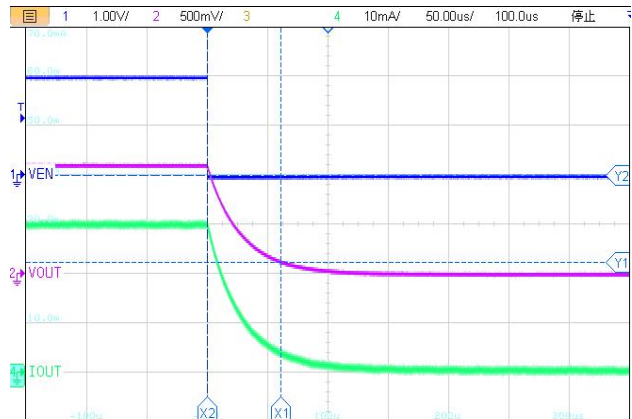

$t_{OFF}=61\mu s(I_{OUT}=30mA)$

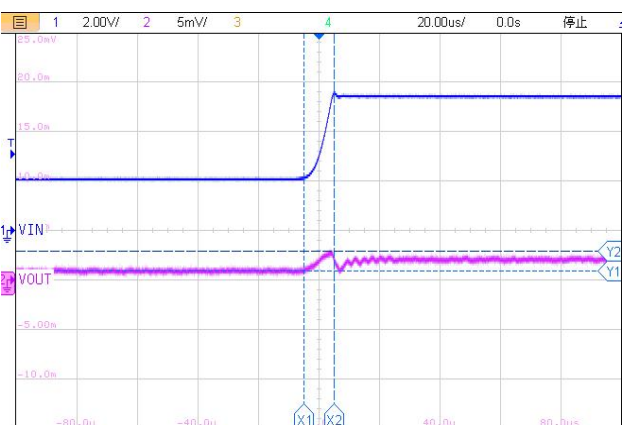

Line transient(2.1~5.5V, $t=10\mu s$)

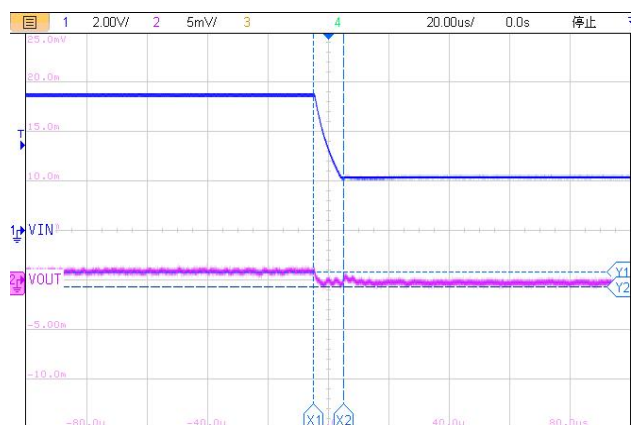

Line transient(5.5~2.1V, $t=10\mu s$)

ET553XX

Typical Characteristics(continued)

$V_{IN} = V_{SET} + 1.0V$, $I_{OUT} = 1mA$, $C_{IN} = C_{OUT} = 2.2\mu F$, (unless otherwise noted). $T_A = 25^\circ C$.

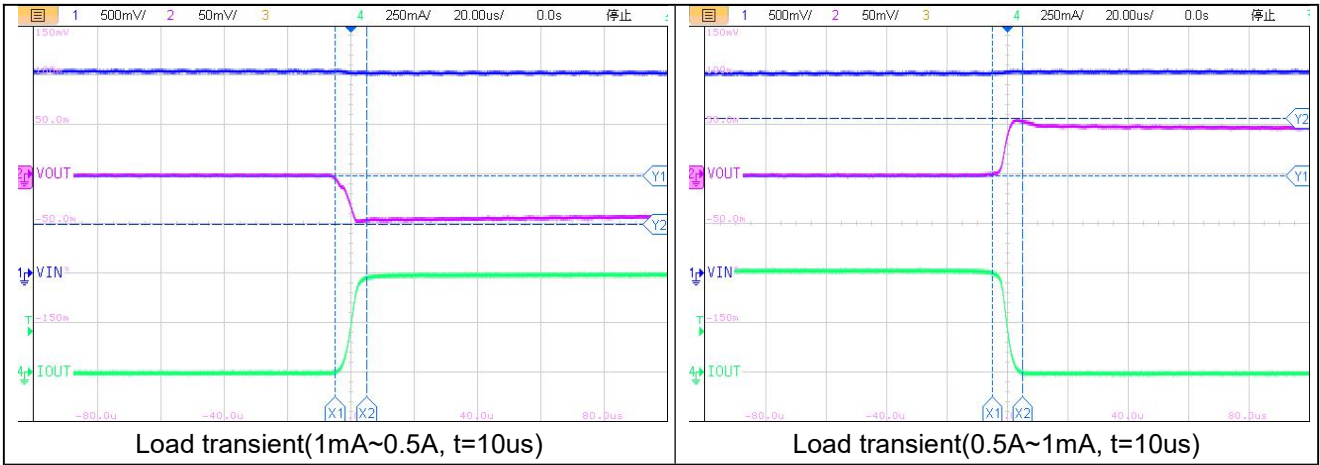

ET553XX

Typical Characteristics(continued)

(2) VOLTAGE VERSION 1.8V

$V_{IN} = V_{SET} + 1.0V$, $I_{OUT} = 1mA$, $C_{IN} = C_{OUT} = 2.2\mu F$, (unless otherwise noted). $T_A = 25^\circ C$.

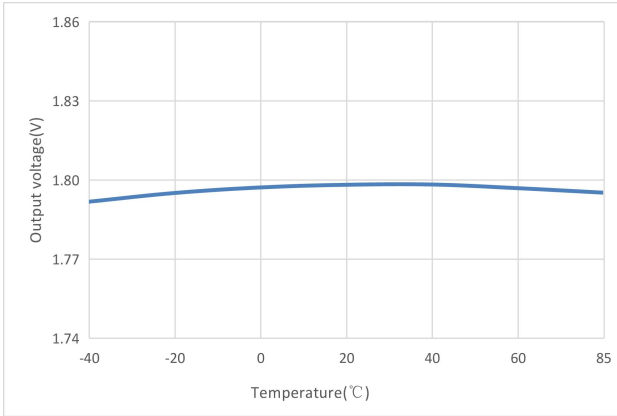

Output Voltage VS Temperature

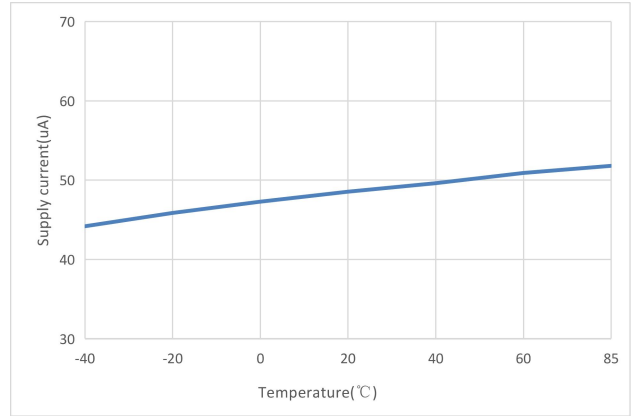

Supply Current VS Temperature

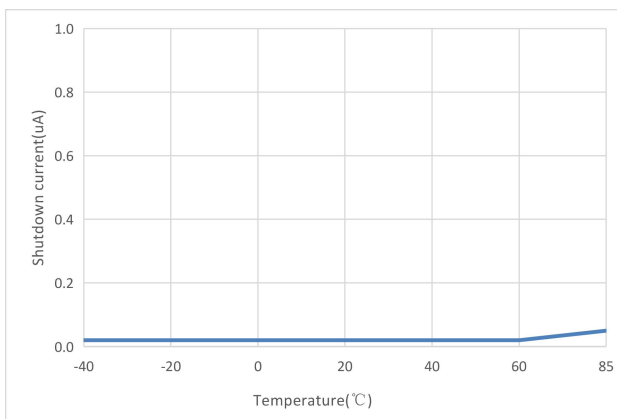

Shutdown Current VS Temperature

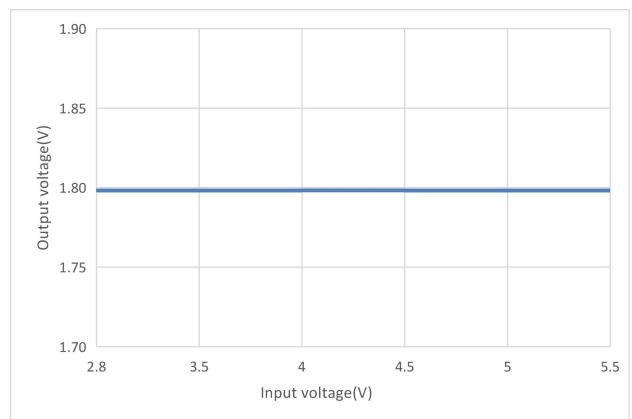

Output Voltage VS Input Voltage

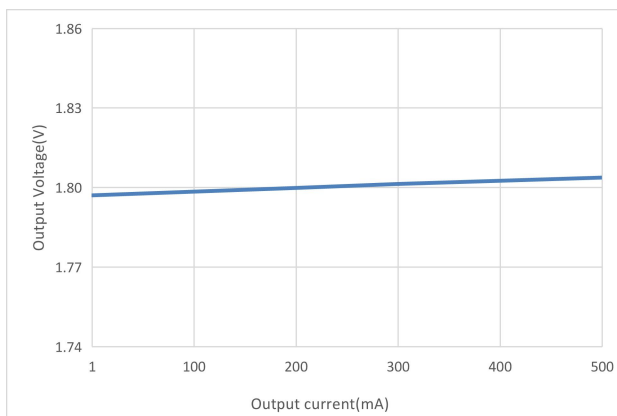

Output Voltage VS Output Current

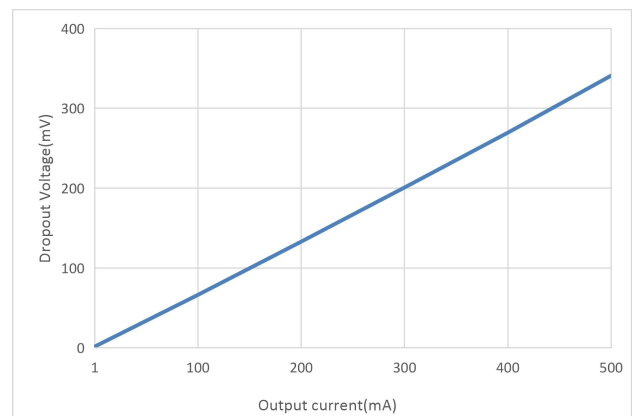

Dropout Voltage VS Output Current

ET553XX

Typical Characteristics(continued)

$V_{IN} = V_{SET} + 1.0V$, $I_{OUT} = 1mA$, $C_{IN} = C_{OUT} = 2.2\mu F$, (unless otherwise noted). $T_A = 25^{\circ}C$.

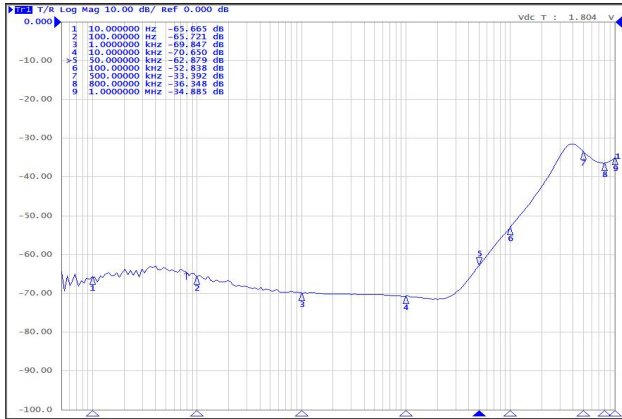

PSRR Test($I_{OUT}=30mA$)

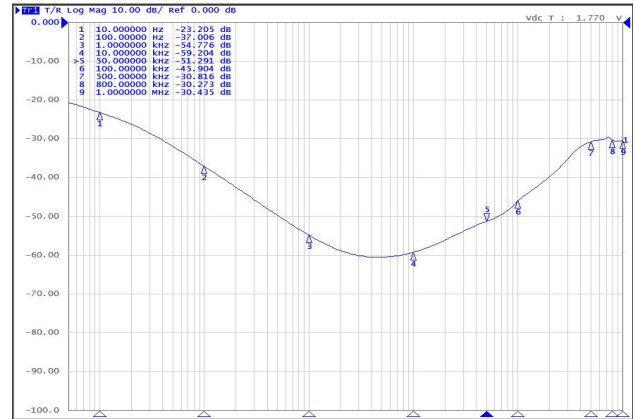

PSRR Test($I_{OUT}=0.5A$)

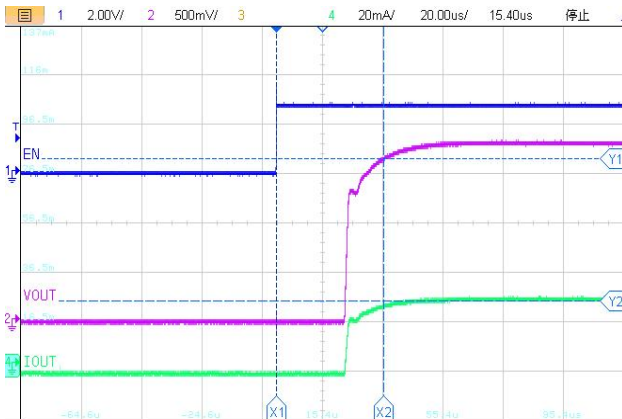

$t_{ON}=35.8\mu s$ ($I_{OUT}=30mA$)

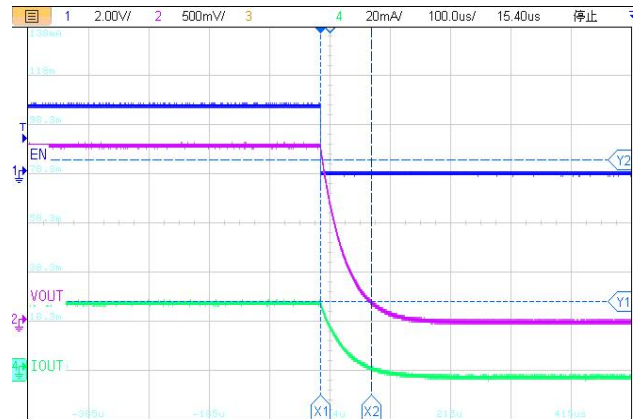

$t_{OFF}=84\mu s$ ($I_{OUT}=30mA$)

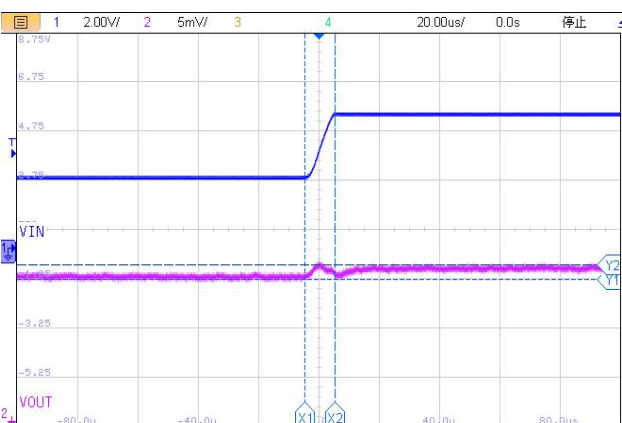

Line transient(2.8~5.5V, $t=10\mu s$)

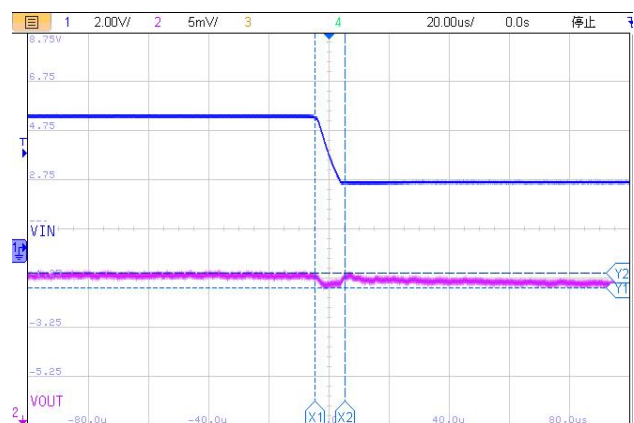

Line transient(5.5~2.8V, $t=10\mu s$)

ET553XX

Typical Characteristics(continued)

$V_{IN} = V_{SET} + 1.0V$, $I_{OUT} = 1mA$, $C_{IN} = C_{OUT} = 2.2\mu F$, (unless otherwise noted). $T_A = 25^\circ C$.

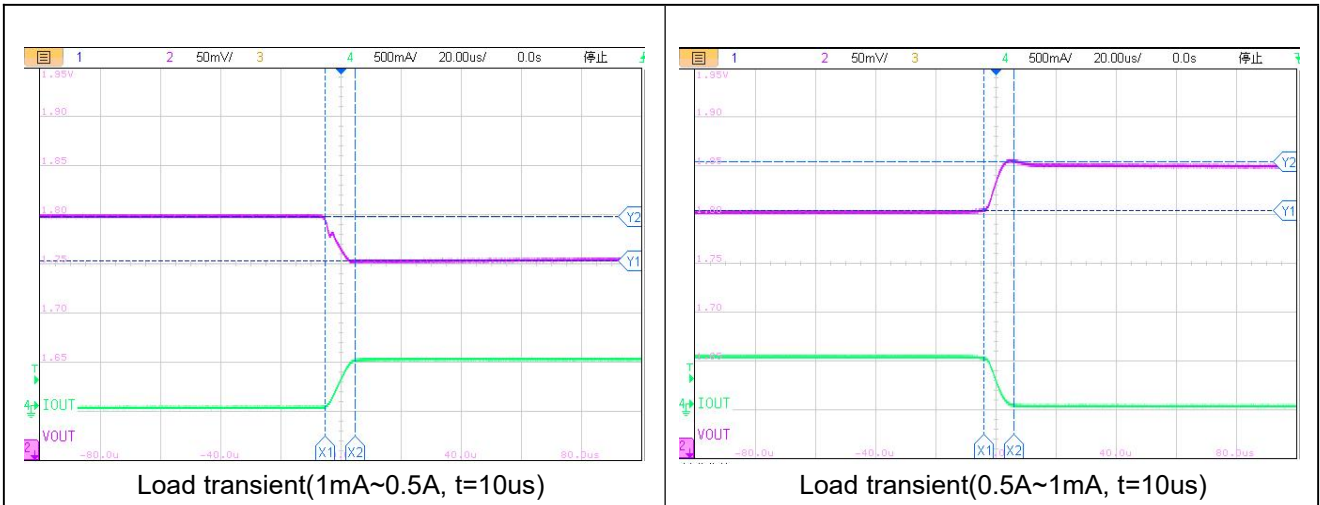

ET553XX

Typical Characteristics(continued)

(3)VOLTAGE VERSION 3.3V

$V_{IN} = V_{SET} + 1.0V$, $I_{OUT} = 1mA$, $C_{IN} = C_{OUT} = 2.2\mu F$, (unless otherwise noted). $T_A = 25^{\circ}C$.

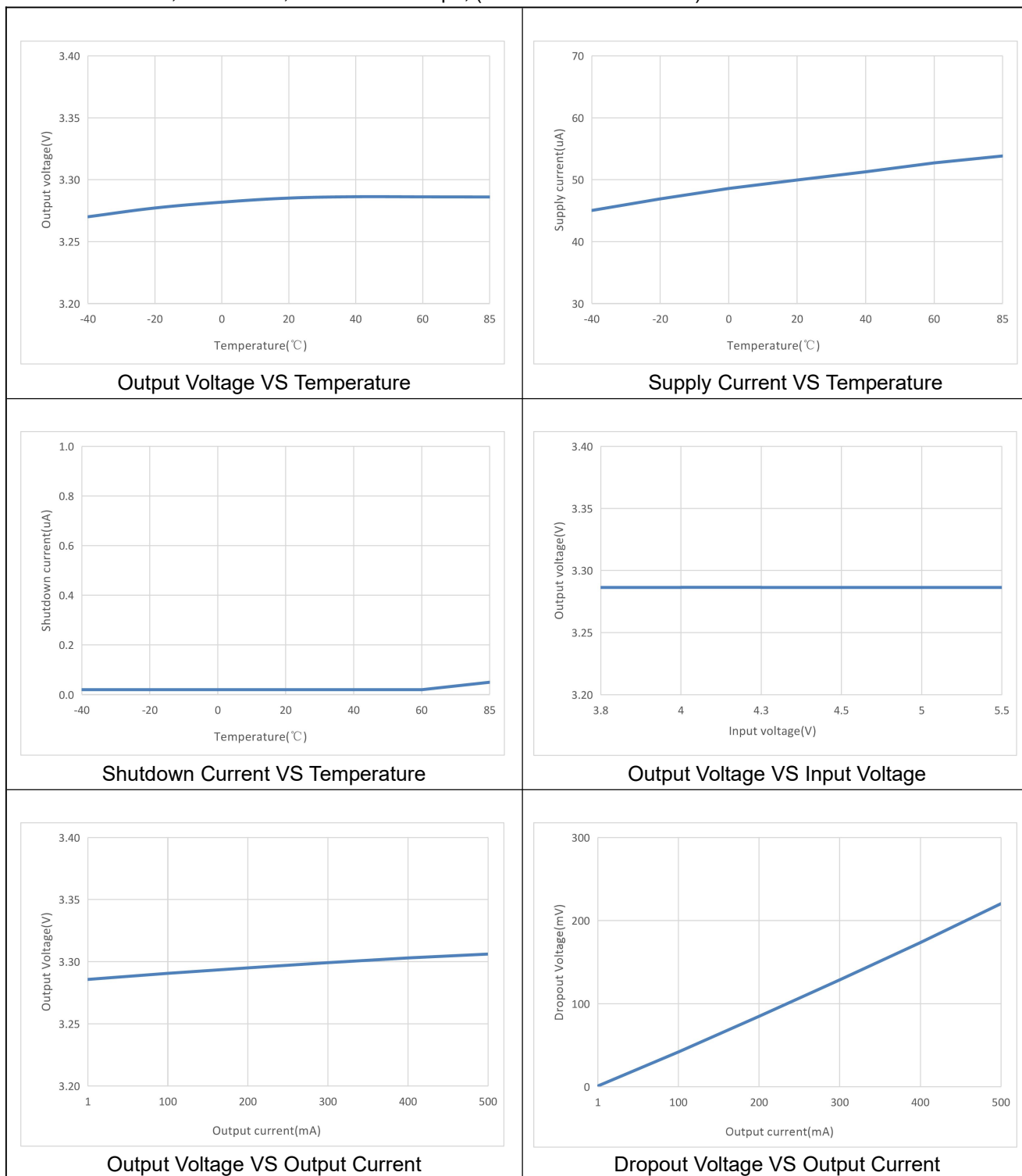

ET553XX

Typical Characteristics(continued)

$V_{IN} = V_{SET} + 1.0V$, $I_{OUT} = 1mA$, $C_{IN} = C_{OUT} = 2.2\mu F$, (unless otherwise noted). $T_A = 25^{\circ}C$.

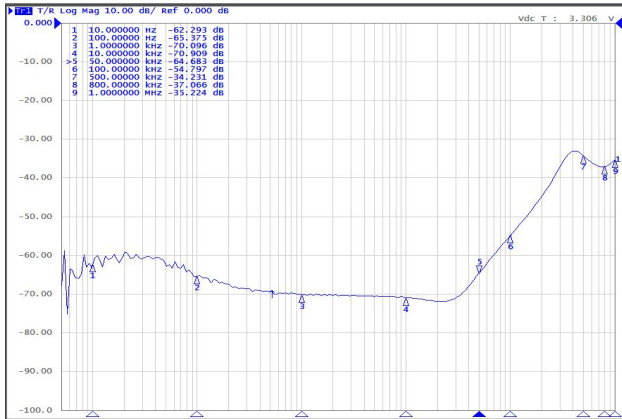

PSRR Test($I_{OUT}=30mA$)

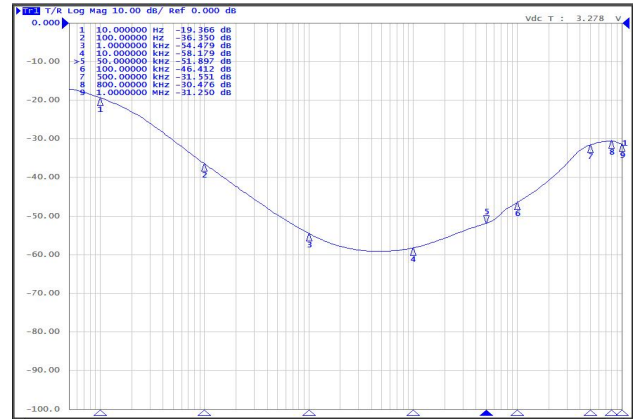

PSRR Test($I_{OUT}=0.5A$)

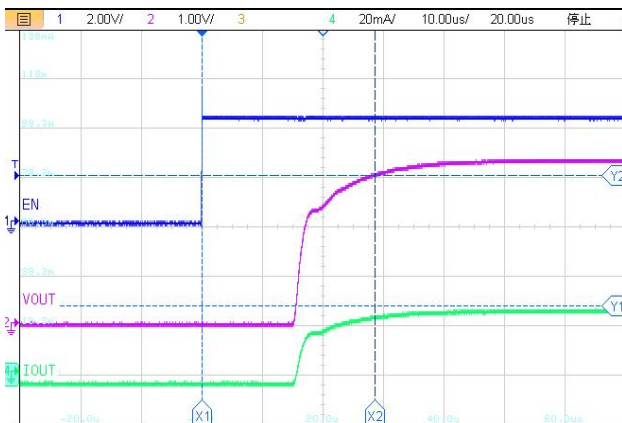

$t_{ON}=28.6\mu s$ ($I_{OUT}=30mA$)

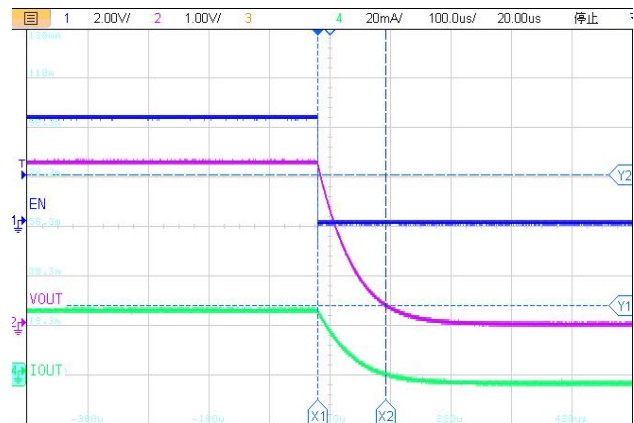

$t_{OFF}=112\mu s$ ($I_{OUT}=30mA$)

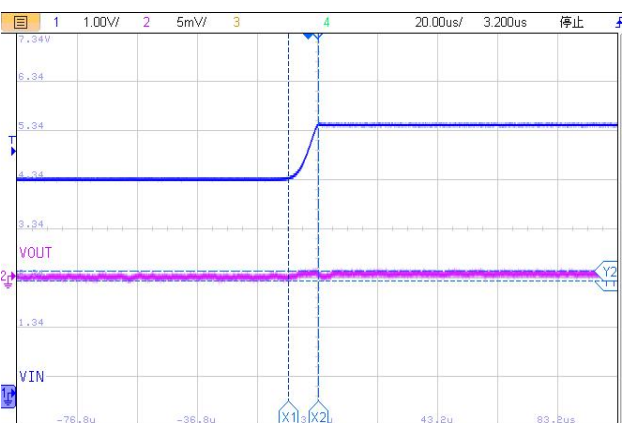

Line transient(4.3~5.5V, $t=10\mu s$)

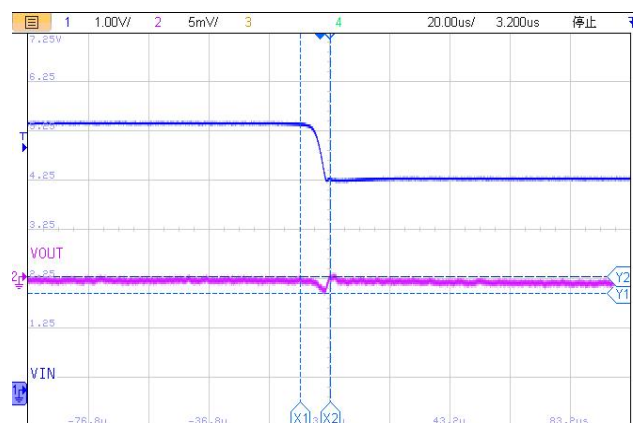

Line transient(5.5~4.3V, $t=10\mu s$)

ET553XX

Typical Characteristics(continued)

$V_{IN} = V_{SET} + 1.0V$, $I_{OUT} = 1mA$, $C_{IN} = C_{OUT} = 2.2\mu F$, (unless otherwise noted). $T_A = 25^\circ C$.

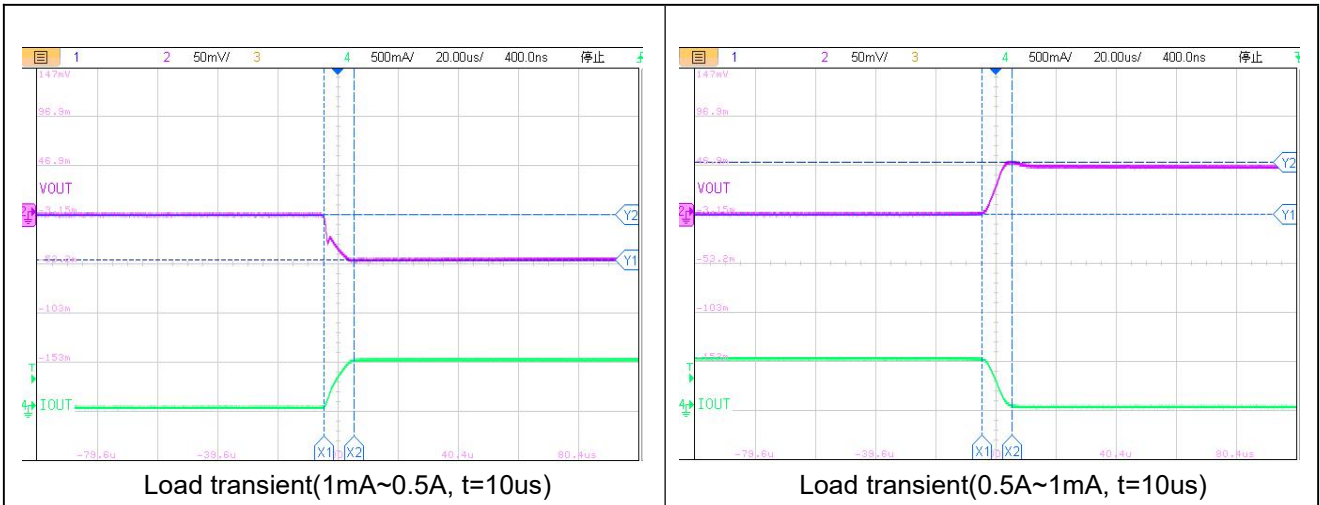

ET553XX

Application Circuits

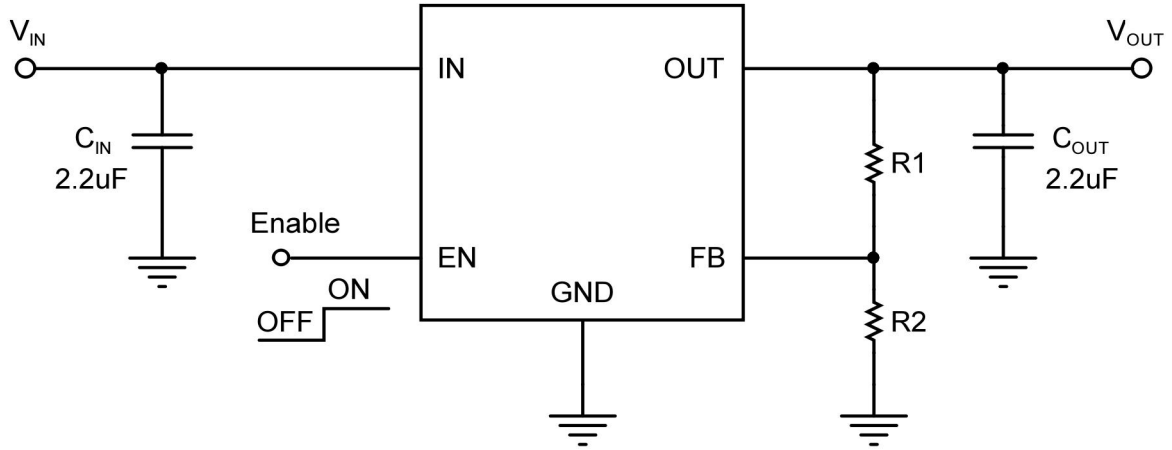

ET553ADJ (ADJ version)

*: $V_{OUT} = (1 + R1/R2) \times 0.8V$, R2 recommend 100K Ω ~ 1M Ω .

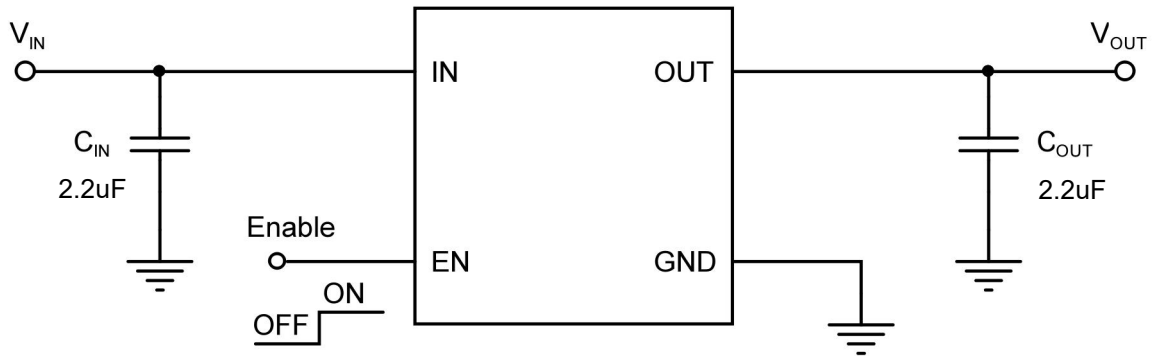

ET553XX (Fixed version)

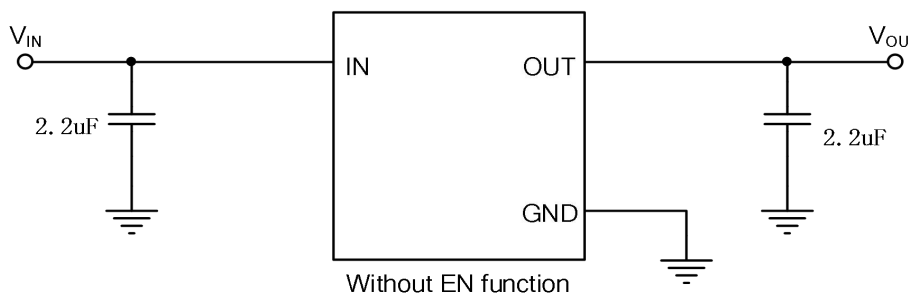

Without EN function

ET553XX (Fixed version)

ET553XX

Package Dimension

DFN4 (1mm × 1mm)

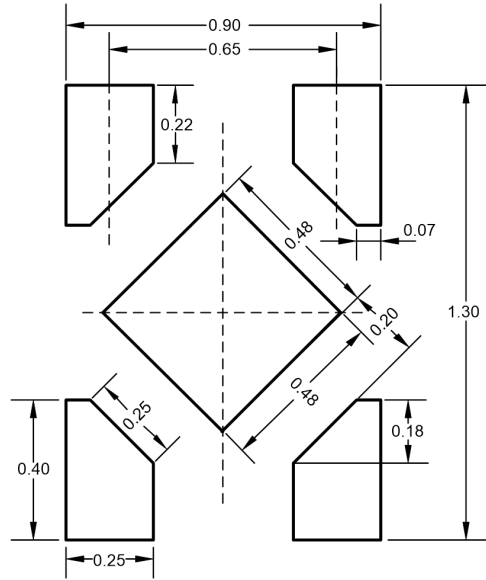
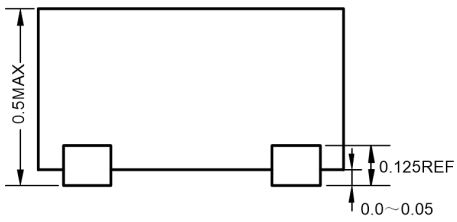
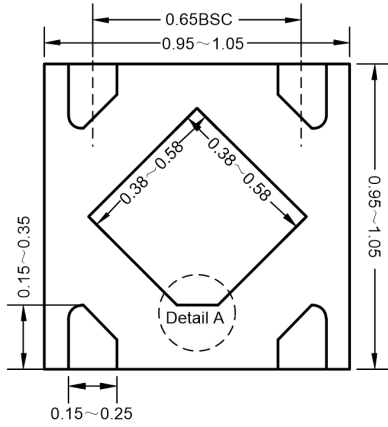

Recommended Land Pattern

Detail A: (PIN1 shape)

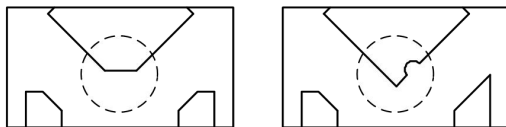

Unit: mm

ET553XX

DFN4 (1.2mm × 1.2mm)

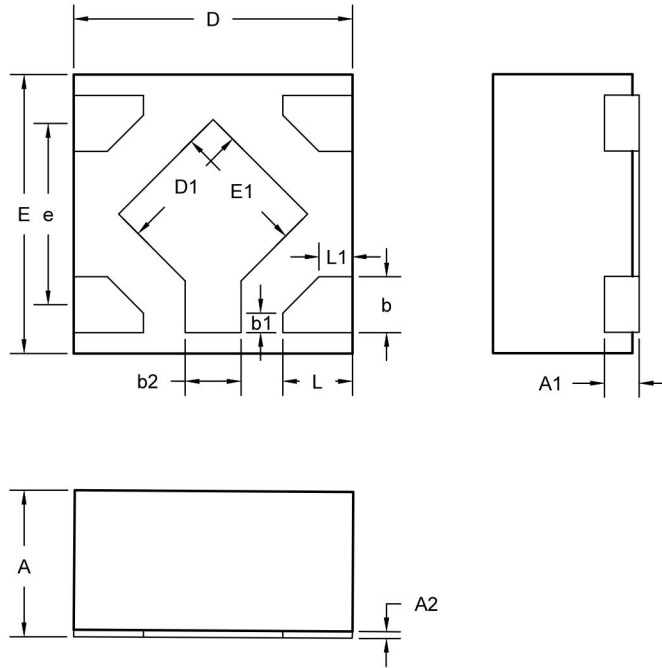

COMMON DIMENSIONS
(UNITS OF MEASURE=MILLIMETER)

SYMBOL	MIN	NOM	MAX
A	0.35	0.40	0.45
A1	0.13REF		
A2	0.00	0.02	0.05
b	0.25	0.30	0.35
b1	0.12REF		
b2	0.15	0.20	0.25
D	1.15	1.20	1.25
D1	0.58	0.63	0.68
E	1.15	1.20	1.25
E1	0.58	0.63	0.68
e	0.8BSC		
L	0.25	0.30	0.35
L1	0.12REF		

ET553XX

SOT23-3

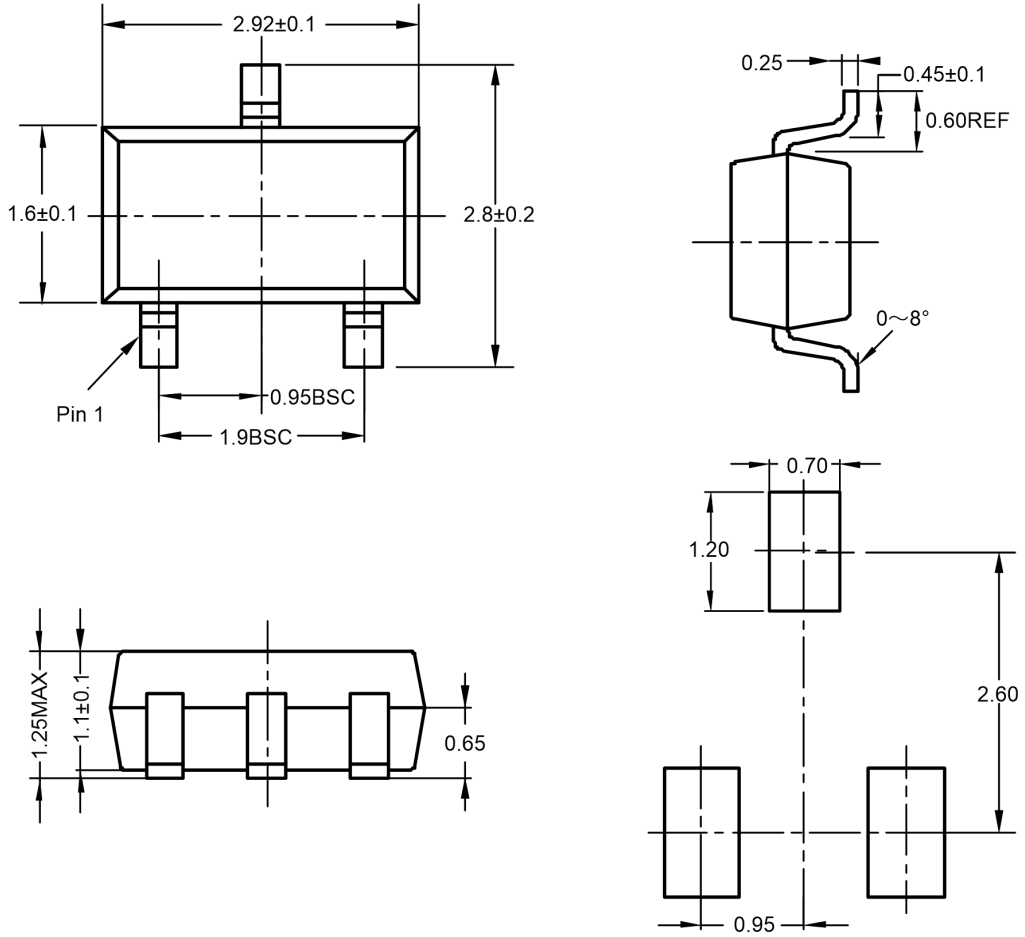

Recommended Land Pattern

Unit: mm

ET553XX

SOT23-5

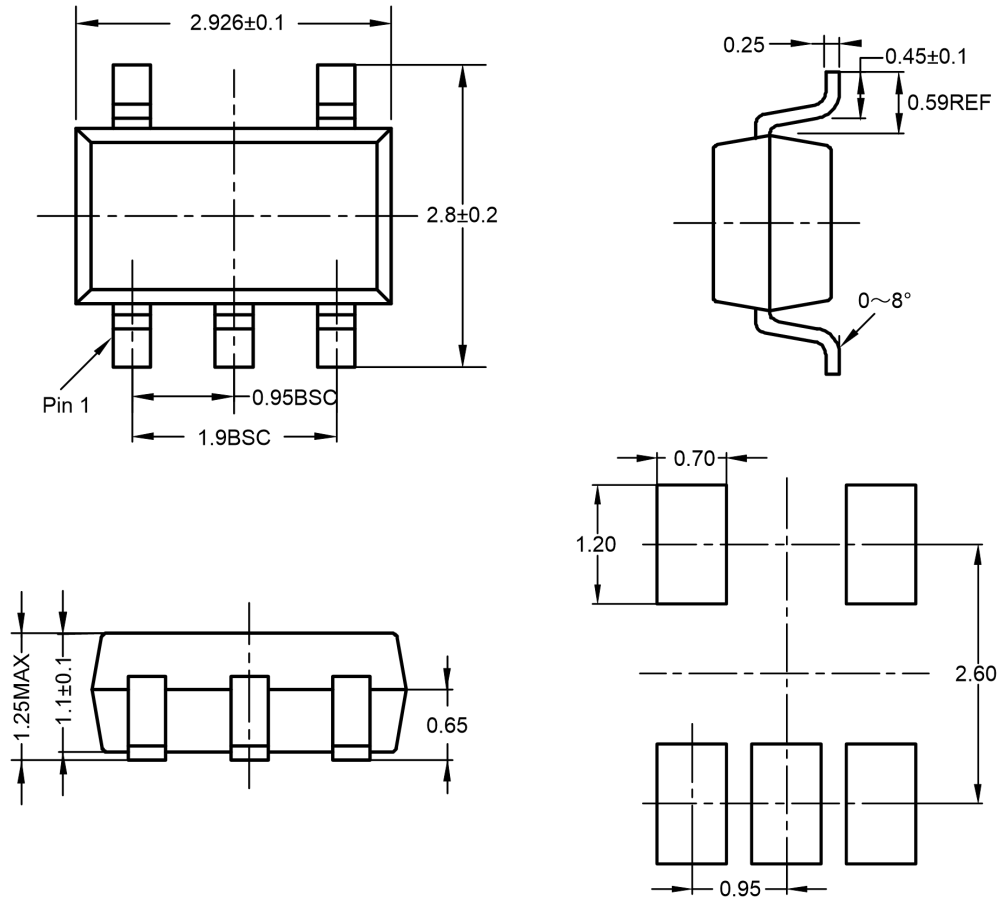

Recommended Land Pattern

Unit: mm

ET553XX

SC70-5

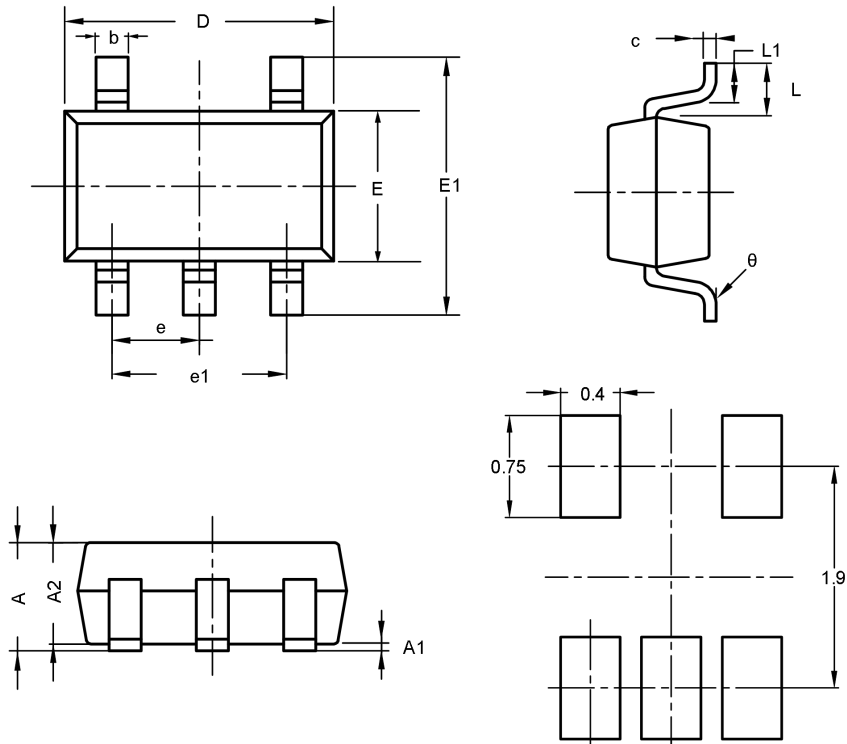

Unit: mm

COMMON DIMENSIONS
(UNITS OF MEASURE=MILLIMETER)

SYMBOL	MIN	NOM	MAX
A	0.8	1	1.1
A1	0	0.05	0.1
A2	0.8	0.9	1
b	0.15	0.25	0.35
c	0.08	0.15	0.22
D	2	2.1	2.2
E	1.15	1.25	1.35
E1	2.15	2.3	2.45
e	0.65TYP		
e1	1.3BSC		
L	0.525REF		
L1	0.26	0.36	0.46
θ	0°	4°	8°

ET553XX

SOT89-3

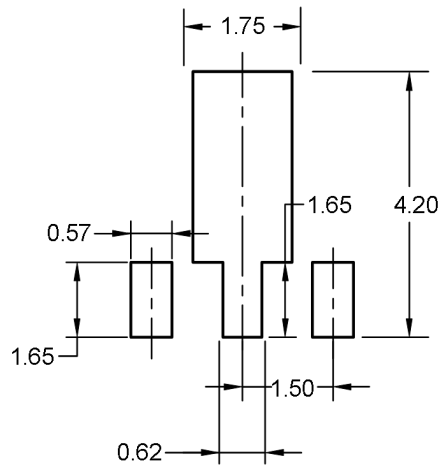
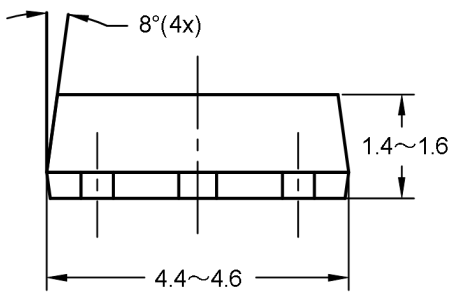
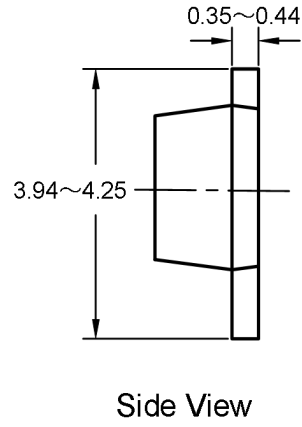
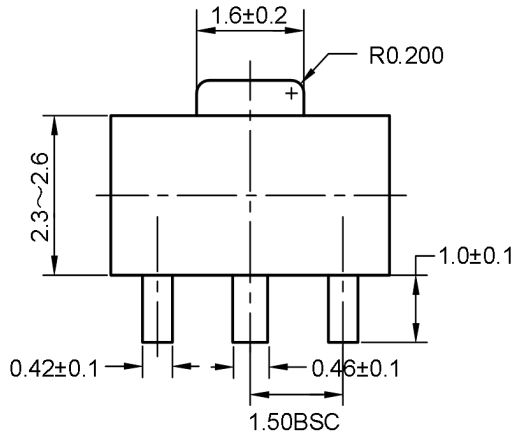

Unit: mm

ET553XX

SOT89-5

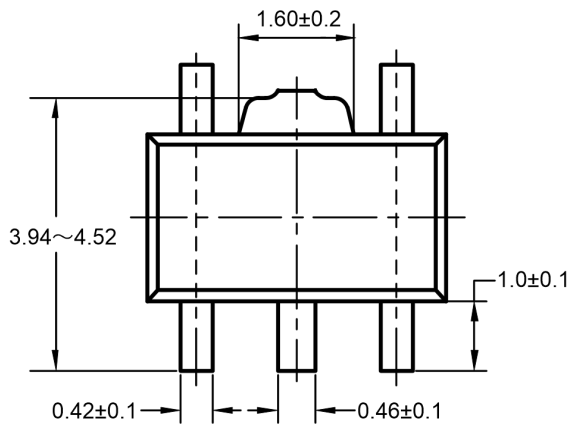

Top View

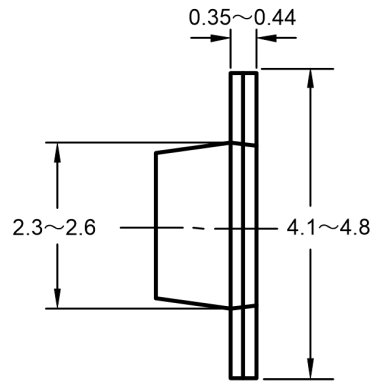

Side View

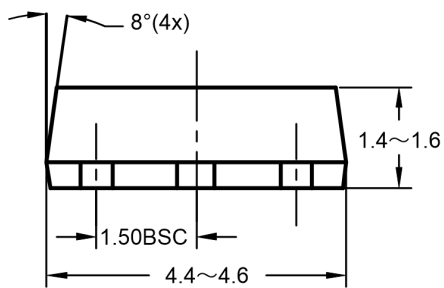

Side View

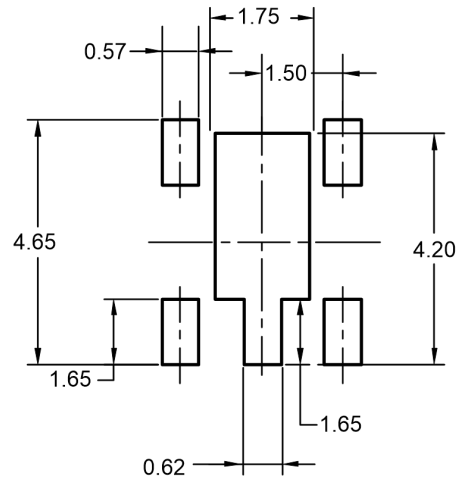

Recommended Land Pattern

Unit: mm

ET553XX

Revision History and Checking Table

Version	Date	Revision Item	Modifier	Function & Spec Checking	Package & Tape Checking
0	2021-8-11	Preliminary Version	Liuxm	Liuxm	Liujiy
1.0	2022-5-18	Official version	Shibo	Liuxm	Liujiy
1.1	2022-7-18	Add SOT89-5DFN4(1.2X1.2)	Shibo	Liuxm	Liujiy
1.2	2023-3-13	Add MSL, ESD, Lu information	Wangpeng	Liuxm	Liujiy
1.3	2023-10-10	Update package picture	Shibo	Liuxm	Liujiy
1.4	2025-2-28	Add SC70-5	Yuyifan	Yangxiaoxu	Liujiy
1.5	2025-4-11	Add SOT89-3,SOT23-3	Yuyifan	Yangxiaoxu	Liujiy